

SHINDAIWA OWNER'S/OPERATOR'S MANUAL

AH2510 ARTICULATED HEDGE TRIMMER



WARNING!

Always wear eye and ear protection when operating this machine! To minimize the risk of injury to yourself and others, read this manual and familiarize yourself with its contents.

shindaiwa

Part Number 62640-94313 Rev. 3/07

Introduction

The Shindaiwa AH2510 Articulated Hedge Trimmer is designed and built to deliver superior performance and reliability without compromise to quality, comfort, safety or durability.

Shindaiwa's high-performance engines represent the leading edge of all position 4-cycle engine technology, delivering exceptionally high power with remarkably low displacement and weight. As an owner/operator, you'll soon discover for yourself why Shindaiwa is simply in a class by itself!

IMPORTANT!

The information contained in these instructions describes machines available at the time of publication. While every attempt has been made to provide the latest information about your Shindaiwa product, there may be some differences between your AH2510 and what is described here. Shindaiwa Inc. reserves the right to make changes to products without prior notice and without obligation to make alterations to machines previously manufactured.

Shindaiwa Inc. reserves the right to make changes to products without prior notice, and without obligation to make alterations to units previously manufactured.

Contents

Page

Introduction	2
Attention Statements	2
Safety Instructions	2
Safety Equipment and Labels.....	3
Operating Precautions.....	3
Operating the Hedge Trimmer.....	4
Product Description.....	5
Specifications.....	5
Assembly.....	6
Adjusting the Cutter Assembly.....	7
Engine Fuel.....	8
Starting the Engine.....	9
Stopping the Engine	10
Adjusting Engine Idle	10
Maintenance	11
Long Term Storage	14
Troubleshooting Guide	15
Emission System Warranty.....	17

Attention Statements

Throughout this manual are special attention statements.

DANGER!

A statement preceded by the triangular attention symbol and the word "DANGER" indicates an imminently hazardous situation which, if not avoided, WILL result in death or serious injury!

WARNING!

A statement preceded by the triangular attention symbol and the word "WARNING" indicates a potentially hazardous situation which, if not avoided, COULD result in death or serious injury.

CAUTION!

A statement preceded by the word "CAUTION" contains information that should be acted upon to avoid damage to the machine.

IMPORTANT!

A statement preceded by the word "IMPORTANT" is one that possesses special significance.

NOTE:

A statement preceded by the word "NOTE" contains information that is handy to know and may make your job easier.



Read and follow this manual, make sure anyone using the trimmer does likewise. Failure to do so could result in serious personal injury or machine failure. Keep this manual for future reference.



Always wear a hard hat to reduce the risk of head injuries during operation of this machine. In addition, always wear eye and hearing protection. Shindaiwa recommends wearing a face shield as additional face and eye protection.



This product conducts electricity. Keep the product and/or operator a minimum distance of 15 feet (4.5 meters) away from electrical sources and power lines.



Keep bystanders at least 50 feet (15 meters) away from the operating trimmer to reduce the risk of being struck by falling objects or thrown debris.



The blades are SHARP! Handle with care.

Safety Instructions



DANGER!



THE ARTICULATED HEDGE TRIMMER IS NOT INSULATED AGAINST ELECTRICAL SHOCK!

Approaching or contacting electrical lines with the trimmer could cause death or serious injury. Keep the trimmer at least 33 feet (10 meters) away from electrical lines or branches that contact electrical lines.



WARNING!

The engine exhaust from this product contains chemicals known to the State of California to cause cancer, birth defects or other reproductive harm.

An articulated hedge trimmer has the potential to do serious damage if misused, abused or mishandled. To reduce the risk of injury, you must maintain control at all times, and observe all safety precautions during operation. *Never permit a person without training or instruction to operate this trimmer!*

Stay Alert

You must be physically and mentally fit to operate this unit safely.



WARNING!



Never operate power equipment of any kind if you are tired or if you are under the influence of alcohol, drugs, medication or any other substance that could affect your ability or judgement.

IMPORTANT!

The procedures described in this manual are intended to help you get the most from your machine as well as to protect you and others from harm. These procedures are guidelines for safe operation under most conditions, and are not intended to replace any safety rules and/or laws that may be in force in your area. If you have questions regarding your power tool, or if you do not understand something in this manual, your Shindaiwa dealer will be glad to assist you. You may also contact Shindaiwa, Inc. at the address printed on the back of this Manual.

Safety Equipment and Labels

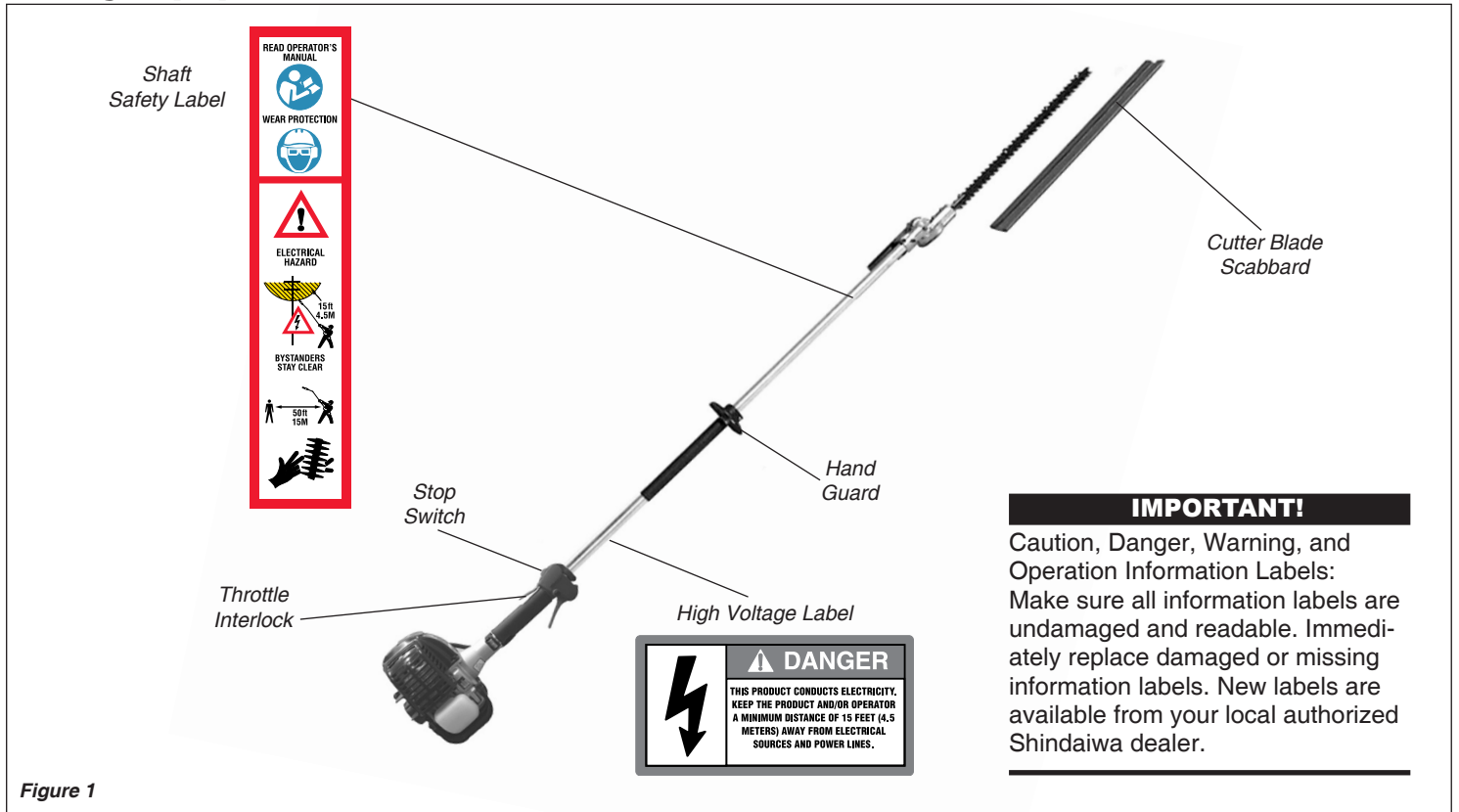

Figure 1

Operating Precautions



WARNING!

- Never transport the articulated hedge trimmer nor set it down with the engine running. An engine that's running could be accidentally accelerated causing the blades to oscillate.
- Make sure the cover is in place when transporting the articulated hedge trimmer.
- When carrying the articulated hedge trimmer by hand, the cutter attachment should be pointing backward with the cutter blade in the retracted or transporting position (see page 7 for articulating adjustment procedures).
- Always make sure the cutter attachment is properly installed and firmly tightened before operation.
- Never use a cracked or warped cutter or cutter bar: replace it with a serviceable one and make sure it fits properly.
- Before starting the engine, make sure the cutter is not contacting anything.
- Always stop the engine immediately and check for damage if you strike a foreign object or if the machine becomes tangled. Do not operate with broken or damaged equipment.
- When cutting a branch that is under tension, be alert for spring-back so that you will not be struck by the moving branch.
- Stop the machine immediately if it suddenly begins to vibrate or shake. Inspect for broken, missing or improperly installed parts or attachments.
- Do not operate the articulated hedge trimmer with the muffler removed.
- Always stop the engine and allow it to cool before refueling. Avoid overfilling and wipe off any fuel that may have spilled.
- Make sure there is always good ventilation when operating the articulated hedge trimmer. Fumes from engine exhaust can cause serious injury or death. Never run the engine indoors!
- Never smoke or light fires near the hedge trimmer. Keep the trimmer away from excessive heat. Engine fuel is very flammable and fire could lead to serious personal injury or property damage.
- Make sure there are no missing or loose fasteners, and that the stop switch and throttle controls are working properly.
- If a cutter should bind fast in a cut, shut off the engine immediately. Push the branch or tree to ease the bind and free the cutter.
- Make sure the cutters are correctly adjusted before operating the articulated hedge trimmer (see page 12 for cutter adjustment procedures). Never attempt cutter adjustment with the engine running!

Operating the Articulated Hedge Trimmer

CAUTION!

- Always maintain the articulated hedge trimmer according to this owner's manual and follow the recommended scheduled maintenance.
- Never modify or disable any of the hedge trimmer's safety devices.
- Always use genuine Shindaiwa parts and accessories when repairing or maintaining this machine.
- Do not make unauthorized modifications to the articulated hedge trimmer.
- Never allow the engine to run at high RPM without a load. Doing so could damage the engine.
- When transporting the hedge trimmer in a vehicle, tie it down securely to prevent fuel spillage or damage to the machine.
- Always stop the engine and allow it to cool before refueling. Avoid overfilling and wipe off any fuel that may have spilled.
- Never place flammable material close to the engine muffler and never run the engine without the spark arrestor screen in place.
- Always clear your work area of trash or hidden debris to help ensure good footing.
- Keep the cutters sharp and properly adjusted.
- Keep the articulated hedge trimmer as clean as possible. Keep it free of loose vegetation, mud, etc.

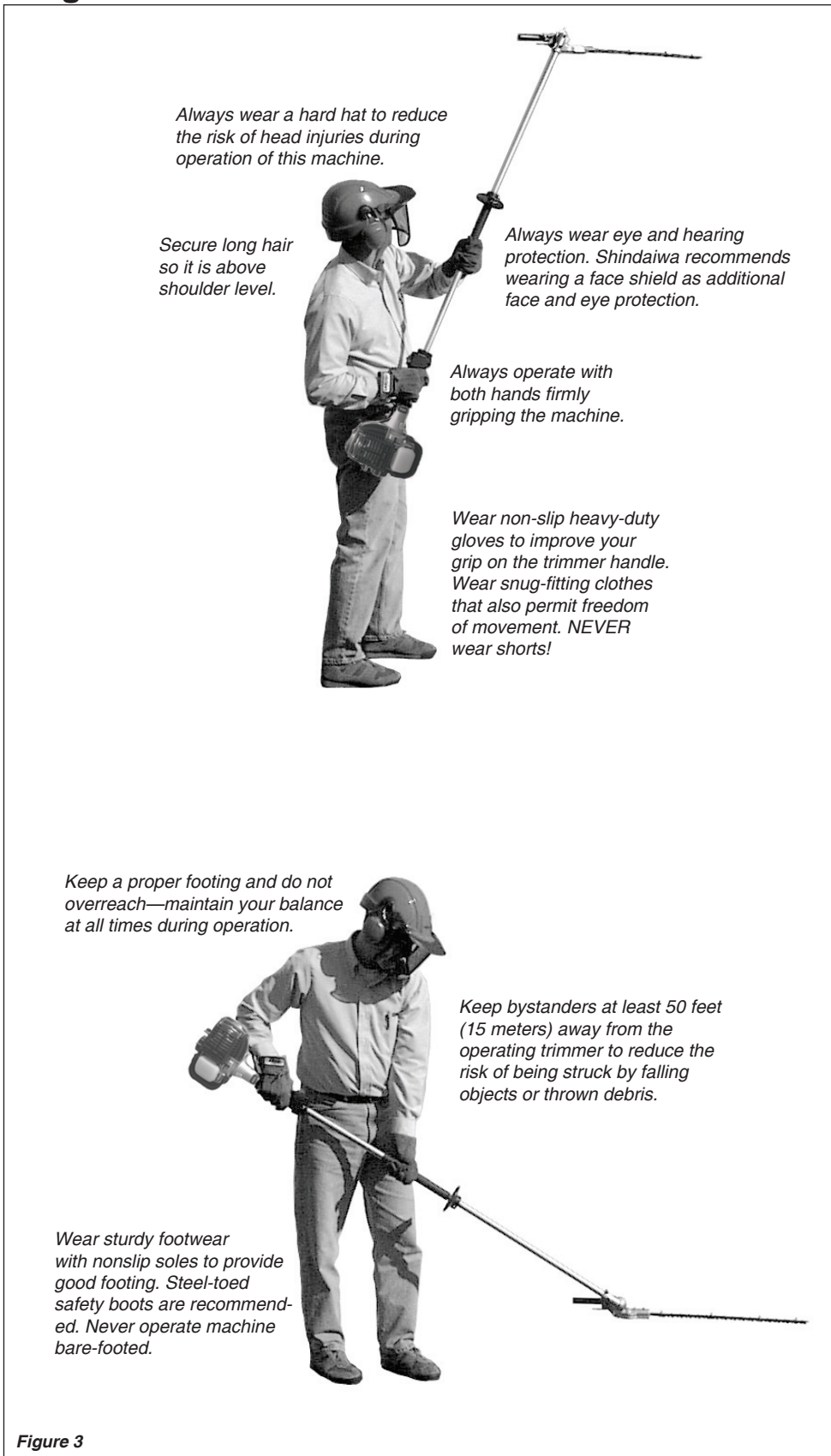
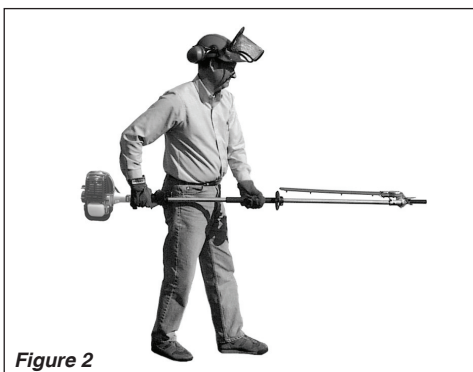

Prior To Assembly

Using Figure 4 as a guide, familiarize yourself with the Shindaiwa AH2510 articulated hedge trimmer and its various components. Understanding your machine helps ensure top performance, longer service life, and safer operation.

Before assembling, make sure you have all the components required for a complete unit:

- Engine assembly
- Outer tube/cutter assembly
- Kit with this manual and tool kit for routine maintenance.
- Cutter blade scabbard

Carefully inspect all components for damage.



WARNING!

Do not make unauthorized modifications or alterations to your articulated hedge trimmer or its components.

IMPORTANT!

The terms “left”, “left-hand”, and “LH”; “right”, “right-hand”, and “RH”; “front” and “rear” refer to directions as viewed by the operator during normal operation.

Product Description

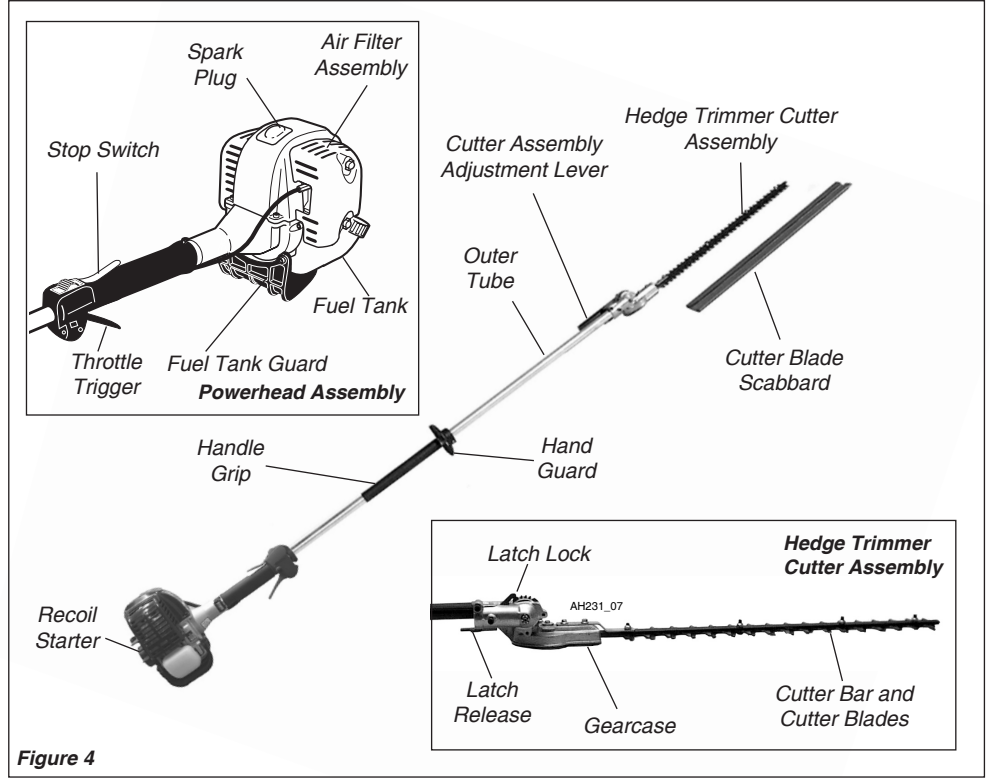

Figure 4

Specifications

Model Name	AH2510
Engine Model	SF2510E
Engine Type	4-cycle, vertical cylinder, air cooled
Dry Weight	14.0 lbs./6.3 kg
Bore x Stroke.....	34 x 27 mm/1.34 X 1.06"
Displacement.....	24.5 cc/1.5 cu. in.
Engine Speed at Maximum Power Output.....	7,500 rpm (min ⁻¹)
Maximum Power Output.....	1.1 hp/0.8 kW
Engine Speed at Idling	3,000 rpm (min ⁻¹)
Maximum Engine Speed	10,500 rpm (min ⁻¹)
Fuel/Oil Ratio.....	50:1 with Premium 2-cycle air cooled mixing oil
Fuel Tank Capacity	590 ml/20 oz.

Carburetor	Walbro WYL diaphragm type
Ignition System	Fully electronic, program controlled
Spark Plug.....	NGK CMR5H
Air Filter.....	Non-reversible, heavy-duty, two-stage filter element
Starting Method.....	Recoil starter
Stopping Method.....	Slide switch
Cooling System	Forced air
Transmission Type	Automatic, centrifugal clutch with bevel gear
Blade Length	22.3 in/567 mm
Cutter Drive.....	Spur gear
Gear Lubricant.....	Lithium based grease

Standard Equipment: Tool kit containing a spark plug wrench, 4 mm hex wrench, and 8 x 10 mm spanner

Optional Equipment: Harness and bracket

Specifications are subject to change without notice.

Assembly: AH2510

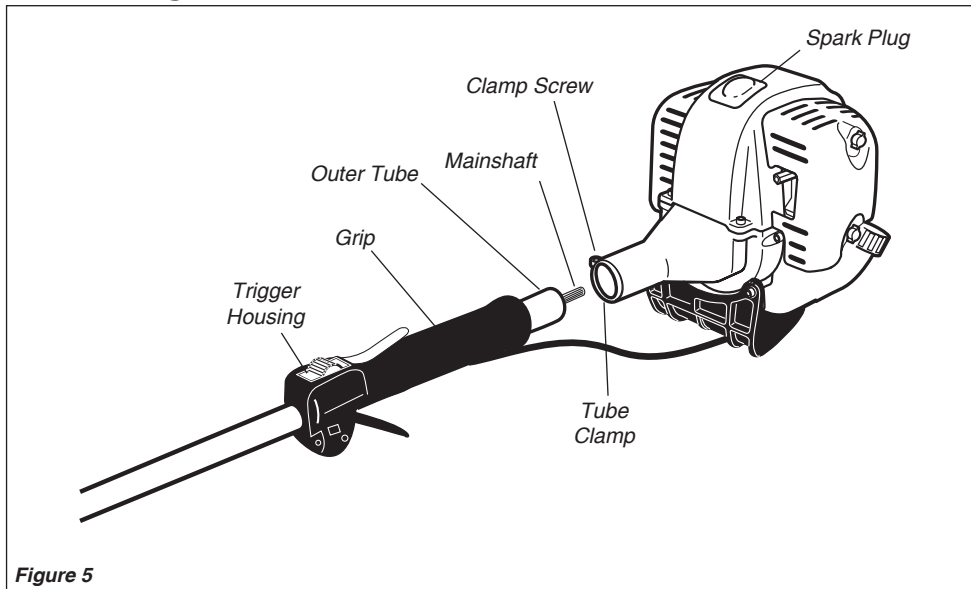

Figure 5

CAUTION!

Do not force the shaft tube into the powerhead! Excessive force can damage the shaft tube and mainshaft.

Connect the Outer Tube to the Powerhead.

1. Place the powerhead on a clean, flat surface, spark plug facing up.
2. Use the 4 mm hex wrench to loosen the tube clamp screw.

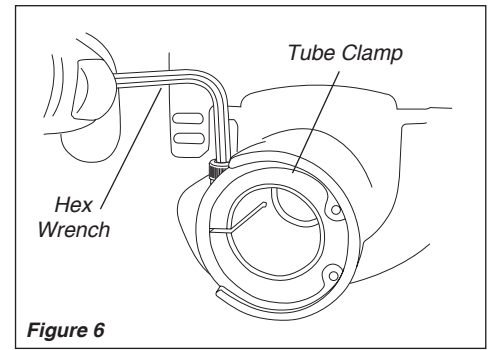

Figure 6

3. Slide the outer tube into the tube clamp until the tube bottoms. If installation is difficult, rotate the outer tube or main shaft slightly until you feel the mainshaft splines engage with the powerhead.
4. Position the outer tube so that the gearcase output shaft is facing left on muffler cover.
5. Slide the outer tube into the powerhead until the throttle grip just contacts the tube clamp.
6. Tighten the clamp screw firmly.

Throttle Cable

Connect the Throttle Cable

1. Loosen the air cleaner cover knob and remove the air cleaner cover. See Figure 7.
2. Slip the throttle cable into the cable adjuster and hook the bullet end of the cable onto the swivel. See Figure 8.

Connect the Ignition Leads

3. Connect the two ignition wires by pushing the bullet connectors together. See Figure 9.
4. Reinstall the air cleaner cover.

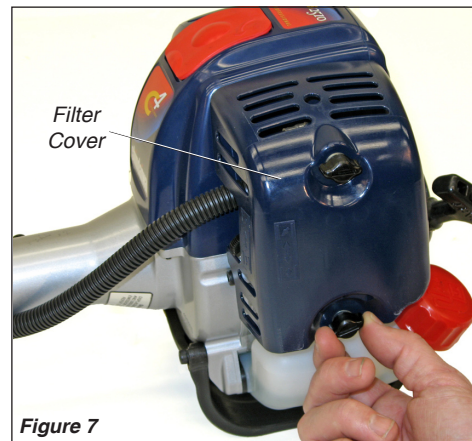

Figure 7

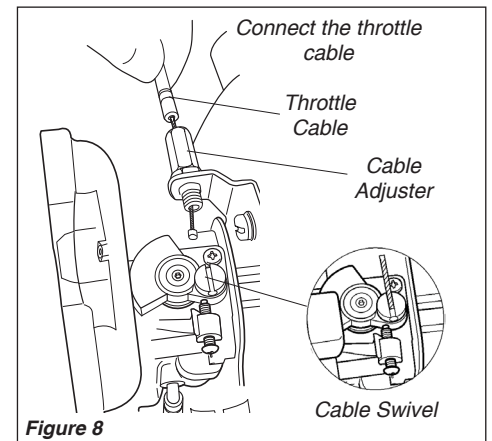

Figure 8

CAUTION!

Routing of wiring must not interfere with throttle or choke operation.

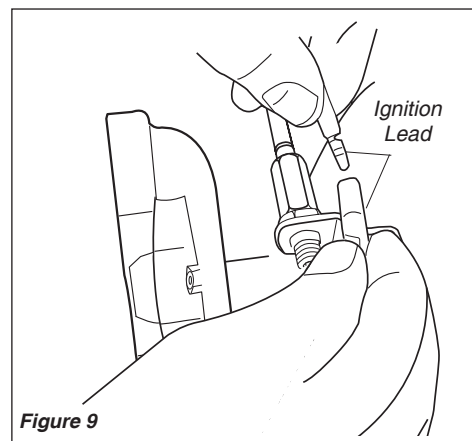

Figure 9

Assembly: Adjust Throttle Lever Free Play

The throttle lever free play should be approximately 3/16-1/4 inch (4-6 mm). See Figure 10. Make sure that the throttle lever operates smoothly without binding. If it becomes necessary to adjust the lever free play, follow the procedures and illustrations that follow.

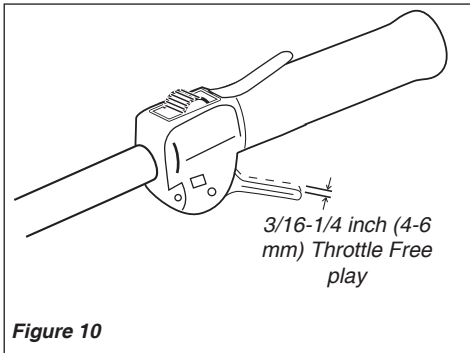

Figure 10

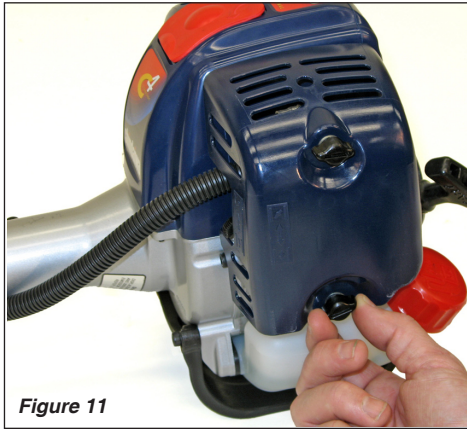

Figure 11

1. Loosen the air cleaner cover knob and remove the air cleaner cover. See Figure 11.
2. Loosen the lock nut on the cable adjuster. See Figure 12.

3. Turn the cable adjuster in or out as required to obtain proper free play 3/16-1/4 inch (4-6 mm). See Figure 12.
4. Tighten the locknut.

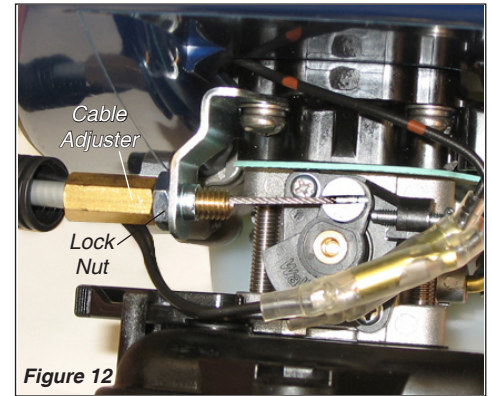

Figure 12

5. Reinstall the air cleaner cover.

Adjusting the Hedge Trimmer Cutter Assembly

WARNING!

- The cutter blades are very sharp. Do not grasp the blades with your hands. Do not brush the blades against your body.
- Never run the engine nor operate the articulated hedge trimmer when the cutter assembly is in the storage/transport position.

IMPORTANT!

Always use gloves when working near the cutter assembly.

Position the hedge trimmer on a flat, level surface with the engine resting on the fuel tank guard. Make sure the scabbard is in place on the blade.

1. With your right hand, grasp the handle, located immediately behind the hand guard. With your left hand, grip the adjustment lever on the cutter assembly. See Figure 13.

IMPORTANT!

The latch lock provides an interlock to help prevent inadvertent depression of the latch release.

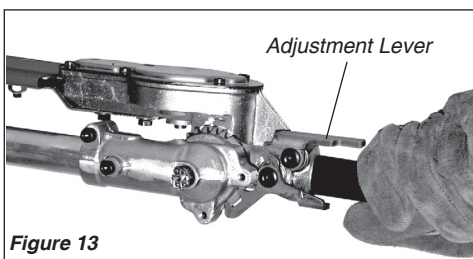

Figure 13

2. With the index finger of your left hand, press the latch release. With your left thumb, press the latch lock. See Figure 14.

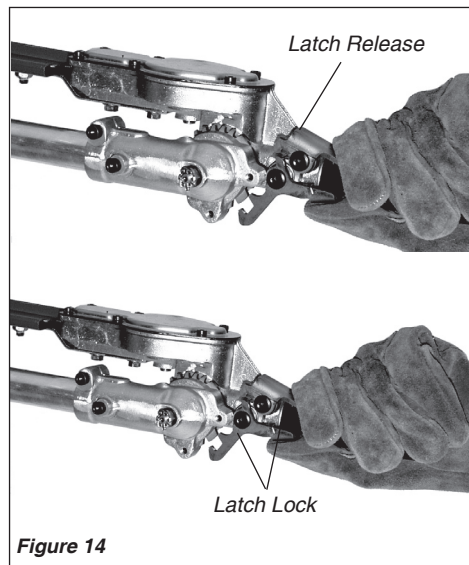

Figure 14

3. While holding the latch lock down, pivot the cutter assembly using the adjustment lever until it is straight with the outer tube (pivot 180°). See Figure 15.

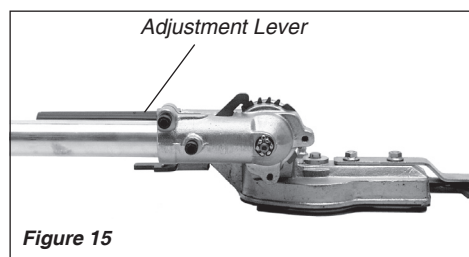

Figure 15

4. Release the latch lock and the latch release. Make sure the latch lock and the latch release return securely to a locking position.
5. Remove the scabbard from the cutter blade. The engine now may be started.

Adjusting the Hedge Trimmer Cutter Assembly for Desired Cutting Angles

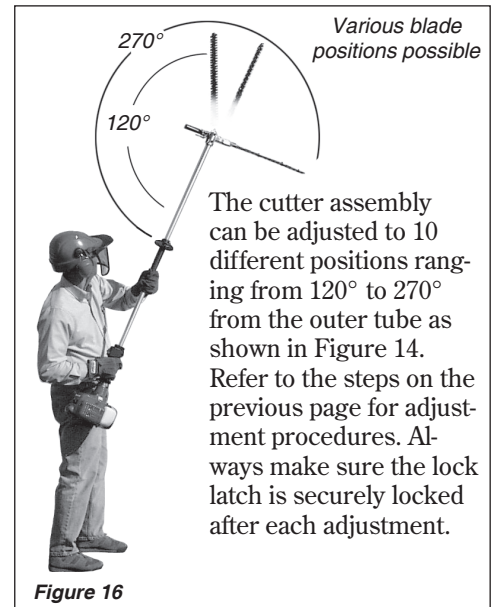

Figure 16

WARNING!

Do not touch the cutter blades when the engine is running. The blades can oscillate even if the engine is idling.

Adjusting the Hedge Trimmer Cutter Assembly (continued)

Adjusting the Cutter Assembly for Storage or Transportation



WARNING!

Never run the engine when adjusting the cutter assembly to the storage position.

1. With the engine off, install the scabbard onto the blade.
2. Using the procedures described on the previous page, rotate the cutter assembly so it is parallel to the tube. Make sure the latch lock and the latch release return securely to a locking position. See Figure 17.
3. Make sure the scabbard is in place on the cutters before storing or transporting.

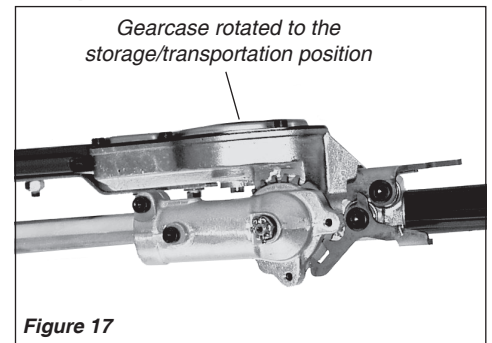

Figure 17

Mixing Fuel

CAUTION!

- Some types of gasoline contain alcohol as an oxygenate. Oxygenated gasoline may cause increased operating temperatures. Under certain conditions, alcohol-based gasoline may also reduce the lubricating qualities of some 2-cycle mixing oils.
- Never use any type of gasoline containing more than 10% alcohol by volume! Generic oils and some outboard oils may not be intended for use in high-performance 2-cycle type engines, and should never be used in your Shindaiwa engine.

CAUTION!

This engine is designed to operate on a 50:1 mixture consisting of unleaded gasoline and ISO-L-EGD or JASO FC class 2-cycle mixing oil only. Use of non-approved mixing oils can lead to excessive carbon deposits.

- Use only fresh, clean unleaded gasoline with a pump octane of 87 or higher.
- Mixed with 50:1 Shindaiwa ISO-L-EGD or JASO FC class 2-cycle mixing oil at a gasoline/ratio of 50:1 (1 gallon of gasoline to 2.6 ozs mixing oil). Shindaiwa One meets or exceeds these requirements.

Examples of 50:1 mixing quantities

- 1 gallon of gasoline to 2.6 oz. mixing oil.
- 5 liters of gasoline to 100 ml. mixing oil.

IMPORTANT!

Mix only enough fuel for your immediate needs! If fuel must be stored longer than 30 days and  oil with fuel stabilizer is not used, it should first be treated with a fuel stabilizer such as STA-BIL™.

 Oil is a registered JASO FC classified oil and also meets or exceeds ISO-L-EGD performance requirements. Shindaiwa One is recommended for use in all Shindaiwa low emissions engines. Shindaiwa One also includes a fuel stabilizer.

Filling the Fuel Tank



WARNING!

Minimize the Risk of Fire!

- **ALWAYS** stop the engine and allow it to cool before refueling. Avoid overfilling and wipe off any fuel that may have spilled.
- Wipe all spilled fuel and move the engine at least 10 feet (3 meters) from the fueling point and source before restarting!
- **NEVER** start or operate this unit if there is a fuel leak.
- **NEVER** start or operate this unit if the carburetor, fuel lines, fuel tank and/or fuel tank cap are damaged.
- **NEVER** smoke or light any fires near the engine or fuel source!
- **NEVER** place any flammable material near the engine muffler!
- **NEVER** operate the engine without the muffler and spark arrester in good working condition.

1. Place the unit on a flat, level surface.
2. Clear any dirt or other debris from around the fuel filler cap.
3. Remove the fuel cap, and fill the tank with clean, fresh fuel.
4. Reinstall the fuel filler cap and tighten firmly.

Starting the Engine

IMPORTANT!

Engine ignition is controlled by a two position switch mounted on the throttle housing labeled, "I" for ON or START and "O" for OFF or STOP.

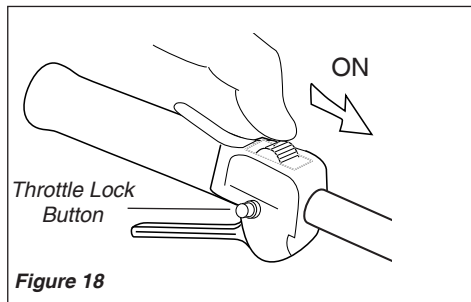

Figure 18

1. Slide the ignition switch to the "ON" position. See Figure 18.
2. Set the throttle lever to the "fast idle";
 - a. Squeeze the throttle lever toward the handgrip on the shaft tube.
 - b. Depress and hold the throttle lock button.
 - c. While depressing the throttle lock button, release the throttle lever. See Figure 18.

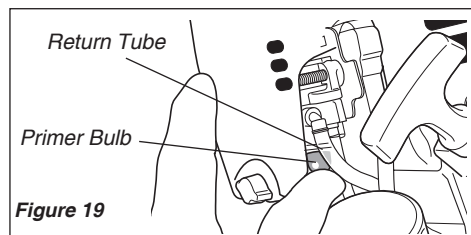

Figure 19

3. Press the primer bulb until fuel can be seen flowing in the transparent return tube.

IMPORTANT!

The primer system only pushes fuel through the carburetor. Repeatedly pressing the primer bulb will not flood the engine with fuel.

4. Set the choke lever to the CLOSED position if engine is cold.



Figure 20

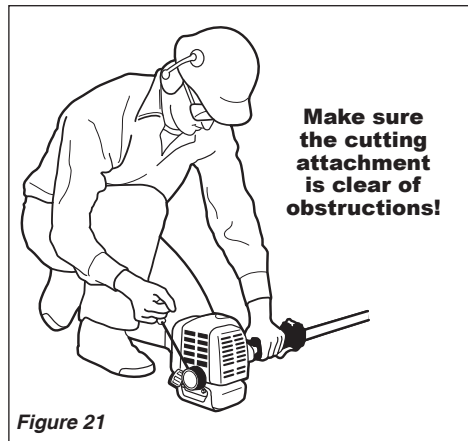

Figure 21

5. While holding the outer tube firmly with left hand. Use your other hand to slowly pull the recoil starter handle until resistance is felt, then pull quickly to start the engine.

CAUTION!

Do not pull the recoil starter to the end of the rope travel. Pulling the recoil starter to the end of the rope travel can damage the starter.



WARNING!

When the engine starts or is running—even at idle—the hedge trimmer cutter blade may move (oscillate). Keep your hands and your body away from the cutter assembly while starting the engine!

5. When the engine starts, slowly move the choke lever to the "OPEN" position. See Figure 22. (If the engine stops after the initial start, close the choke and restart.)



Figure 22



WARNING!

Never start the engine from the operating position.

When the Engine Starts...

- After the engine starts, allow the engine to warm up at idle 2 or 3 minutes before operating the unit.
- Advancing the throttle makes the cutting attachment oscillate faster; releasing the throttle permits the attachment to stop oscillating. If the cutting attachment continues to oscillate when the engine returns to idle, carburetor idle speed should be adjusted (see "Adjusting Engine Idle" on the next page).

IMPORTANT!

If the engine fails to start after several attempts with the choke in the closed position, the engine may be flooded with fuel. If flooding is suspected, move the choke lever to the open position and repeatedly pull the recoil starter to remove excess fuel and start the engine. If the engine still fails to start, refer to the troubleshooting section of this manual.

Starting A Flooded Engine

1. Disconnect the spark plug lead and use the spark plug wrench to remove the spark plug (turn counter clockwise to remove).
2. Slide the ignition switch to the "O" (STOP) position.
 - If the spark plug is fouled or soaked with fuel, clean the plug as necessary.
3. Open the choke (Figure 22) and fully depress the throttle lever with your left hand, then pull the starter handle rapidly with your right hand to clear excess fuel from the combustion chamber.

Stopping the Engine

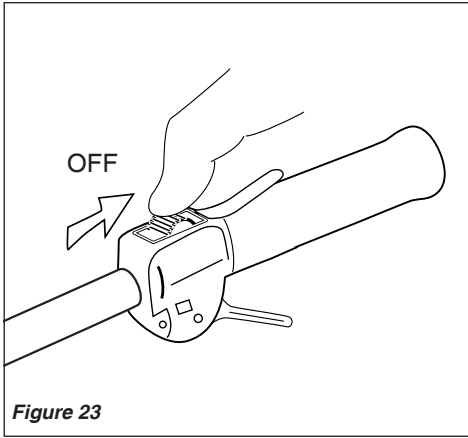

Idle the engine briefly before stopping (about 2 minutes), then slide the ignition switch to the "O" (Engine OFF) position.

Adjusting Engine Idle

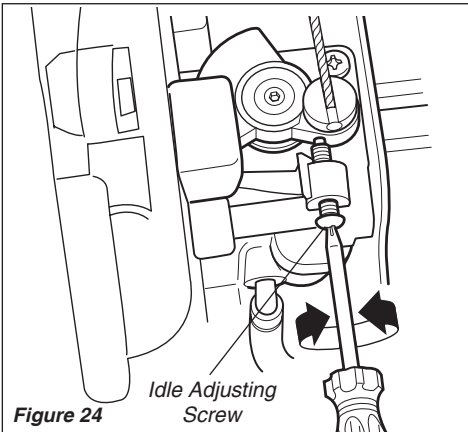

The engine must return to idle speed whenever the throttle lever is released. Idle speed is adjustable, and must be set low enough to permit the engine clutch to disengage the cutting attachment.

Idle Speed Adjustment



WARNING!

The cutting attachment must NEVER oscillate at engine idle! If the idle speed cannot be adjusted by the procedure described here, return the unit to your Shindaiwa dealer for inspection.

3. If a tachometer is available, the engine idle speed should be final adjusted to 3,000 (± 300) rpm (min^{-1}).

NOTE:

Carburetor fuel mixture adjustments are preset at factory and cannot be serviced in the field.

1. Place the unit on the ground and start the engine, then allow it to idle 2-3 minutes until warm.
2. If the cutting attachment oscillates when the engine is at idle, reduce the idle speed by turning the idle adjustment screw counter-clockwise. See Figure 24.

General Maintenance

IMPORTANT!

MAINTENANCE, REPLACEMENT, OR REPAIR OF EMISSION CONTROL DEVICES AND SYSTEM MAY BE PERFORMED BY ANY REPAIR ESTABLISHMENT OR INDIVIDUAL. HOWEVER, WARRANTY REPAIRS MUST BE PERFORMED BY A DEALER OR SERVICE CENTER AUTHORIZED BY SHINDAIWA CORPORATION AND USE OF PARTS THAT ARE NOT EQUIVALENT IN PERFORMANCE AND DURABILITY TO AUTHORIZED PARTS MAY IMPAIR THE EFFECTIVENESS OF THE EMISSION CONTROL SYSTEM AND MAY HAVE A BEARING ON THE OUTCOME OF THE WARRANTY CLAIM.



WARNING!

Before performing any maintenance, repair, or cleaning work on the machine, make sure the engine and cutting attachment are completely stopped. Disconnect the spark plug wire before performing service or maintenance work.



WARNING!

Non-standard parts may not operate properly with your unit and may cause damage and lead to personal injury.

NOTE:

Using non-standard replacement parts could invalidate your Shindaiwa warranty.

Spark Plug

Keep the spark plug and wire connections tight and clean.

Fasteners

Make sure nuts, bolts, and screws (except carburetor adjusting screw) are tight.

Muffler



WARNING!

Operating the engine without a muffler or with a muffler that is damaged or improperly installed can increase engine noise sufficiently to cause hearing loss.

This machine must never be operated with a faulty or missing spark arrestor or muffler. Make sure the muffler is well secured and in good condition. A worn or damaged muffler is a fire hazard and may also cause hearing loss.

Daily Maintenance

Prior to each work day, perform the following:

- Remove all dirt and debris from the engine, check the cooling fins and air cleaner for clogging, and clean as necessary. See Figure 25.

- Carefully remove any accumulations of dirt or debris from the muffler and fuel tank. Check cooling air intake area at base of crankcase. Remove all debris. Dirt build-up in these areas can lead to engine overheating, fire, or premature wear.

- Clean any debris or dirt from the hedge trimmer cutter blades. Lubricate the blades before use and after refueling. Check the cutters for damage or incorrect adjustment.
- Check for loose or missing screws or components. Make sure the cutter attachment is securely fastened.
- Check the entire machine for leaking fuel or grease.
- Make sure nuts, bolts, and screws (except carburetor adjusting screws) are tight.



WARNING!

Always wear gloves when working around the cutter assembly.

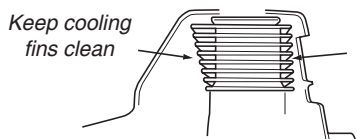

Figure 25

Cutter Blade Adjustment



WARNING!

The cutter blades are very sharp! Always wear gloves when working around the cutter assembly.

CAUTION!

Operating the trimmer with worn or improperly adjusted cutters will reduce cutter performance and may also damage your machine.

Cutter performance of your machine depends in great measure on cutter blade clearance. Properly adjusted blades will oscillate freely yet help prevent binding of cut material between blades. Adjust blades as follows (Figure 26):

1. Loosen all blade locknuts at least one full turn.
2. Tighten each blade shoulder bolt firmly, and then loosen the shoulder bolts 1/4 to 1/2 turn.
3. Working from the gearcase end, lock each bolt in place by firmly tightening its locknut while preventing the shoulder bolt from turning.

When shoulder bolt adjustment is correct, there should be a gap of 0.25–0.50 mm between the cutter blades and the flat washers, and the flat washer beneath each bolt head should turn freely.

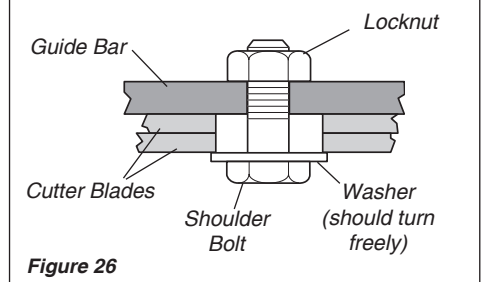

Figure 26

10-Hour Maintenance

(more frequently in dusty conditions)

1. Remove the air cleaner cover by loosening the thumb screws and lifting up. See Figure 27A.
2. Remove and inspect the pre-filter. If the pre-filter is torn or otherwise damaged, replace it with a new one. See Figure 27B.
3. Clean the pre-filter with soap and water. Let dry before reinstalling.
4. Inspect the air cleaner element. If the element is damaged or distorted, replace it with a new one.
5. Tap filter gently on a hard surface to dislodge debris from element or use compressed air from the inside to blow debris out and away from the air filter element.

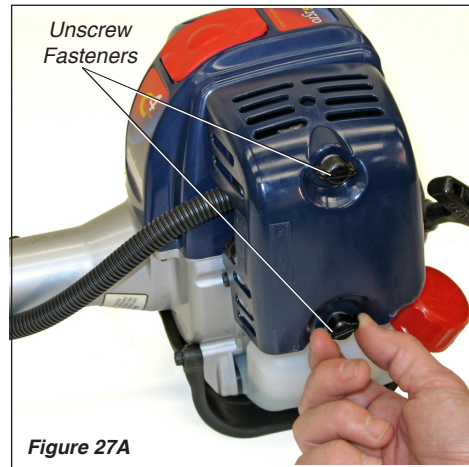

Figure 27A

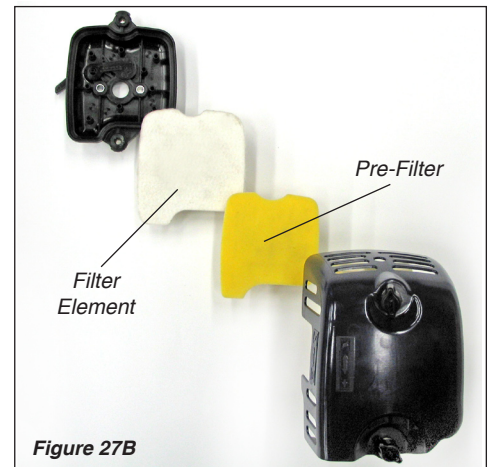

Figure 27B

IMPORTANT!

Direct the air stream at the inside face of the filter only!

6. Install the filter element, pre-filter and cover in the reverse order of removal.

CAUTION!

Never operate the unit if the air cleaner assembly is damaged or missing!

10/15-Hour Maintenance

CAUTION!

Before removing the spark plug, clean the area around the plug to prevent dirt and dust from getting into the engine's internal parts.

Every 10 to 15 hours of operation:

- Remove and clean the spark plug. See Figure 19. Adjust the spark plug electrode gap to 0.024 inch (0.6 mm). If the plug must be replaced, use only: NGK CMR5H or equivalent.
- Lubricate the cutter assembly gearbox by pumping one or two strokes of

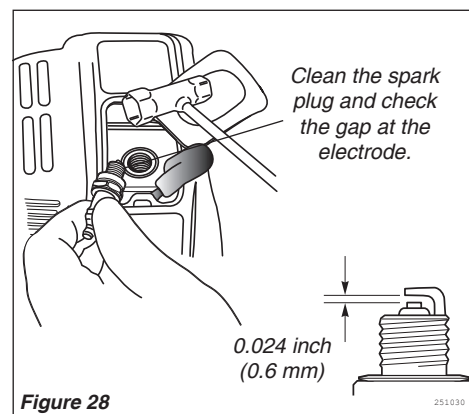

Figure 28

lithium-base grease into the grease fitting using a lever-type grease gun. See Figure 29.

CAUTION!

Over lubricating can cause the gearbox to operate sluggishly and can cause grease to leak out.

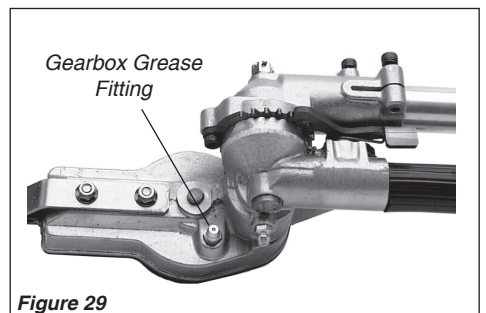

Figure 29

50-Hour Maintenance

Every 50 hours of operation

(more frequently in dusty or dirty conditions):

- Remove and clean the cylinder cover and clean dirt and debris from the cylinder cooling fins.
- **Lubricate the gearcase.** To perform this operation, first remove the gearcase from the outer tube as follows:

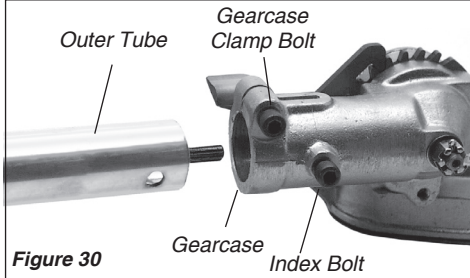

- c. Slide the gearcase out of the tube. Using a grease gun, pump lithium-base grease (about 10 grams) into the grease fitting on the gearcase until you see old grease being purged from the gearcase (Figure 31). Purged grease will be visible in the outer tube cavity. Clean up excess grease, then reassemble the gearcase onto the outer tube. Make sure the index bolt fits into the hole on the outer tube. Securely tighten both bolts.

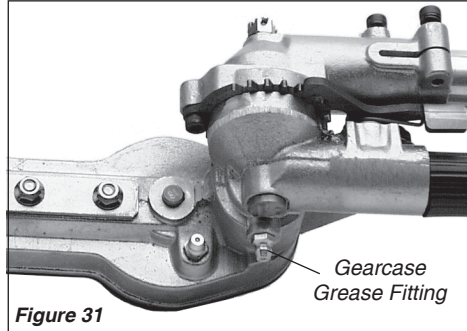

Figure 31

Servicing the fuel filter

CAUTION!

Make sure you do not pierce the fuel line with the end of the hooked wire. The line is delicate and can be damaged easily.

- Use a wire hook to extract the fuel filter from inside the fuel tank (Figure 32). Inspect the fuel filter element. If it shows signs of contamination from debris, replace it with a genuine Shindaiwa replacement fuel filter element. Before reinstalling the filter, inspect the fuel line. If you discover damage or deterioration, the unit should be removed from service until it can be inspected by a Shindaiwa-trained service technician.

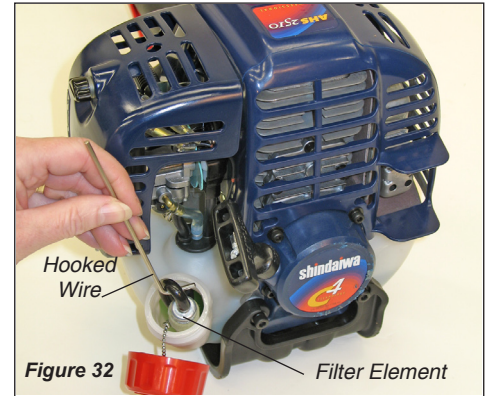

Figure 32

CAUTION!

Do not remove the D-shaped shim washer from the gearcase clamp! The shim washer prevents damage from overtightening the tube clamp screw.

- a. Loosen the gearcase clamp bolt.
- b. Remove the index bolt from the gearcase.

139/150-Hour Maintenance

Maintenance after first 139-hours, then every 150-hours thereafter.

- Combustion chamber should be decarbonized, and the valve clearance should be adjusted. It is highly recommended that this is done by a Shindaiwa-trained service technician.
- Replace the spark plug annually: Use only NGK CMR5H or equivalent resistor type spark plug of the correct heat range. Set spark plug electrode gap to 0.024-0.028 inch (0.6-0.7 mm).

NOTE:

The NGK CMR5H also meets the requirements for electro magnetic compliance (EMC).

CAUTION!

- Performing a valve adjustment incorrectly may cause hard starting and/or can damage the unit. Refer to the C-4 Service Manual for complete valve adjustment procedure and torque specifications.
- If you are unfamiliar with this engine or uncomfortable with this procedure, Consult with an authorized Shindaiwa servicing dealer.

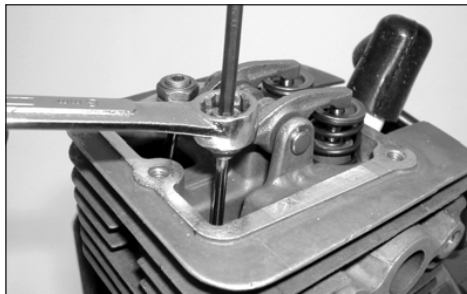

Valve Adjustment

1. Remove cylinder cover, rocker arm cover, and set piston at TDC-compression.
2. Loosen adjuster locknut so that the 2.5 mm Allen socket head adjustment screw can turn freely.

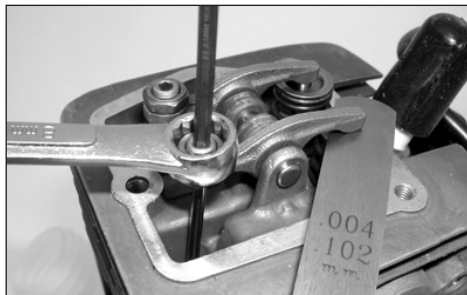

3. Insert feeler gauge .004" (0.10 mm) for both intake and exhaust; between valve stem tip and rocker arm.
4. Turn adjustment screw (clockwise = tighter, counter-clockwise = looser) until

feeler gauge is almost snug. Back off just enough to allow gauge to slip out with limited resistance.

5. While holding adjustment screw in place with Allen driver, tighten locknut with wrench.
6. Turn engine over several times, and return to TDC-compression. Recheck with proper feeler gauge to make sure clearance adjustment did not change as a result of tightening locknut. Readjust as necessary.
7. Replace rocker arm cover gasket to assure proper sealing and install cover.



IMPORTANT!

If new gasket is not available and/or old gasket is not damaged, old gasket may be reused. Never use cracked or damaged gaskets!

Spark Arrester Screen Maintenance

If the engine becomes sluggish and low on power, check and clean the spark arrester screen.



WARNING!

Never operate the unit with a damaged or missing muffler or spark arrester! Operating with missing or damaged spark arrester is a fire hazard and could also damage your hearing.

1. With a 3 mm hex wrench remove the 4 engine cover screws and the engine cover. See Figure 33.
2. With a 4 mm hex wrench remove the 3 muffler bolts and the muffler. See Figure 33.
3. With a small flat bladed screwdriver remove the 2 screws holding the spark arrester screen and cover to the muffler. See Figure 33.
4. Remove the screen and clean it with a stiff bristle brush.
5. Inspect the cylinder exhaust port for any carbon buildup.

IMPORTANT!

If you note excessive carbon buildup, consult with an authorized Shindaiwa servicing dealer.

6. Reassemble the spark arrester, muffler and engine cover in the reverse order of disassembly.

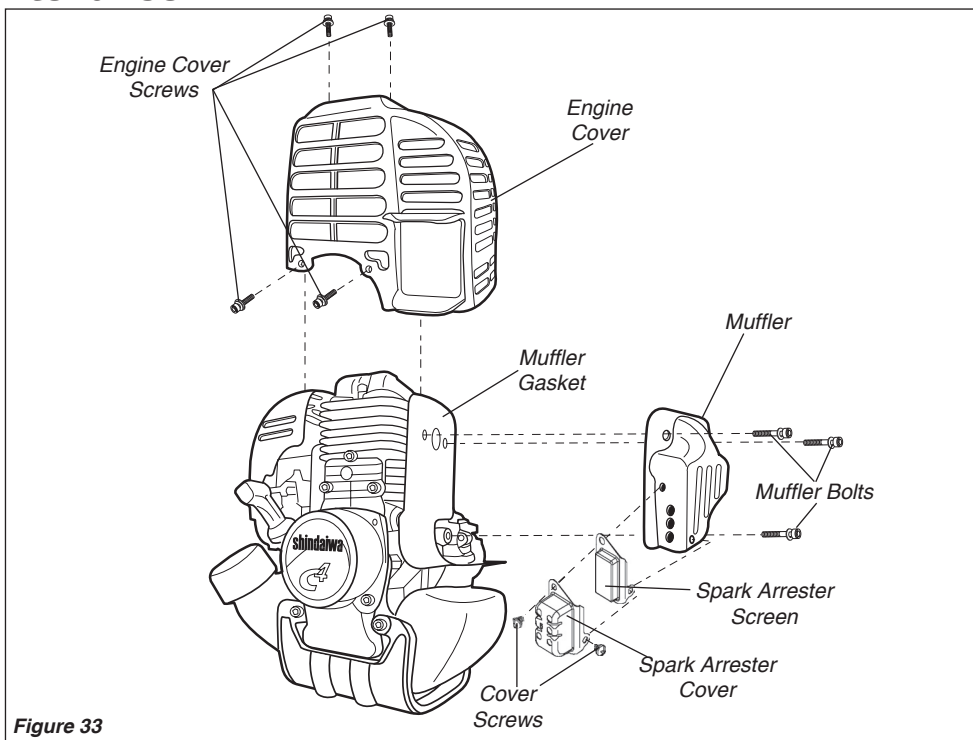

Figure 33

Long Term Storage

Whenever the machine will not be used for 30 days or longer, use the following procedures to prepare it for storage:

- Clean external parts thoroughly and apply a light coating of oil to all metal surfaces.

CAUTION!

Gasoline stored in the carburetor for extended periods can cause hard starting, and could also lead to increased service and maintenance costs.

NOTE

Damage resulting from stale or contaminated fuel is not covered by the Shindaiwa warranty policy.

- Drain all the fuel from the carburetor and the fuel tank.

IMPORTANT!

All stored fuels should be stabilized with a fuel stabilizer such as STA-BIL™.

- Remove the spark plug and pour about 1/4 ounce of oil into the cylinder through the spark plug hole. Slowly pull the recoil starter 2 or 3 times so oil will evenly coat the interior of the engine. Reinstall the spark plug.
- Before storing the machine, repair or replace any worn or damaged parts.
- Remove the air cleaner element from the carburetor and clean it thoroughly with soap and water. Rinse and dry thoroughly, then add a few drops of oil and work it in. Reassemble.
- Store the machine in a clean, dust-free area.

Troubleshooting Guide

ENGINE DOES NOT START

What To Check	Possible Cause	Remedy
Does the engine crank? YES	NO Faulty recoil starter. Fluid in the crankcase. Internal damage.	Consult with an authorized servicing dealer.
Good compression? YES	NO Loose spark plug. Excess wear on cylinder, piston, rings. Valves not seating.	Tighten and re-test. Consult with an authorized servicing dealer.
Does the tank contain fresh fuel of the proper grade? YES	NO Fuel incorrect, stale, or contaminated; mixture incorrect.	Refill with fresh, clean unleaded gasoline with a pump octane of 87 or higher mixed with a 2-cycle air cooled mixing oil that meets or exceeds ISO-L-EGD and/or JASO FC classified oils at 50:1 gasoline/oil ratio.
Is fuel visible and moving in the return line when priming? YES	NO Check for clogged fuel filter and/or vent. Priming pump not functioning properly.	Replace fuel filter or vent as required; restart. Consult with an authorized servicing dealer.
Is there spark at the spark plug wire terminal? YES	NO The ignition switch is in "O" (OFF) position. Shorted ignition ground. Faulty ignition unit.	Move switch to "I" (ON) position and re-start. Consult with an authorized servicing dealer.
Check the spark plug.	If the plug is wet, excess fuel may be in the cylinder. The plug is fouled or improperly gapped. The plug is damaged internally or of the wrong size.	Crank the engine with the plug removed, reinstall the plug, and restart. Clean and regap the plug to 0.024 - 0.028 inch (0.6 - 0.7 mm). Restart. Replace the plug with an NGK CMR5H or equivalent resistor type spark plug of the correct range. Set spark plug electrode gap to 0.024 - 0.028 inch (0.6-0.7 mm).

LOW POWER OUTPUT

What To Check	Possible Cause	Remedy
Is the engine overheating?	Operator is overworking the unit. Carburetor mixture is too lean. Improper fuel ratio. Fan, fan cover, cylinder fins dirty or damaged. Carbon deposits on the piston or in the muffler.	Cut at a slower rate. Consult with an authorized servicing dealer. Refill with fresh, clean unleaded gasoline with a pump octane of 87 or higher mixed with a 2-cycle air cooled mixing oil that meets or exceeds ISO-L-EGD and/or JASO FC classified oils at 50:1 gasoline/oil ratio. Clean, repair or replace as necessary. Consult with an authorized servicing dealer.
Engine is rough at all speeds. May also have black smoke and/or unburned fuel at the exhaust.	Clogged air cleaner element. Loose or damaged spark plug. Air leakage or clogged fuel line. Water in the fuel. Piston seizure. Faulty carburetor and/or diaphragm. Valve clearance set incorrectly.	Service the air cleaner element. Tighten or replace. Repair or replace fuel filter and/or fuel line. Replace the fuel. See page 8. Consult with an authorized servicing dealer.
Engine is knocking.	Overheating condition. Improper fuel. Carbon deposits in the combustion chamber. Valve clearance set incorrectly.	See above. Check fuel octane rating; check for presence of alcohol in the fuel (page 8). Refuel as necessary. Consult with an authorized servicing dealer.

Troubleshooting Guide (continued)

ADDITIONAL PROBLEMS

Symptom	Possible Cause	Remedy
Poor acceleration.	<ul style="list-style-type: none"> Clogged air filter. Clogged fuel filter. Lean fuel/air mixture. Idle speed set too low. 	<ul style="list-style-type: none"> Clean the air filter. Replace the fuel filter. Consult with an authorized servicing dealer. Adjust: 3,000 (\pm300) RPM (min^{-1}).
Engine stops abruptly.	<ul style="list-style-type: none"> Switch turned off. Fuel tank empty. Clogged fuel filter. Water in the fuel. Shorted spark plug or loose terminal. Ignition failure. Piston seizure. 	<ul style="list-style-type: none"> Reset the switch and restart. Refuel. See page 8. Replace fuel filter. Drain; replace with clean fuel. See page 8. Clean or replace spark plug, tighten the terminal. Replace the ignition unit. Consult with an authorized servicing dealer.
Engine difficult to shut off.	<ul style="list-style-type: none"> Ground (stop) wire is disconnected, or switch is defective. Overheating due to incorrect spark plug. Overheated engine. 	<ul style="list-style-type: none"> Test and replace as required. Idle engine until cool. Clean and regap the plug to 0.024 - 0.028 inch (0.6 - 0.7 mm). Correct plug: NGK CMR5H or equivalent resistor type spark plug of the correct range. Idle engine until cool.
Top of engine is getting dirty and oily.	<ul style="list-style-type: none"> Valve cover is leaking. 	<ul style="list-style-type: none"> Consult with an authorized servicing dealer.
Cutting attachment rotates at engine idle.	<ul style="list-style-type: none"> Engine idle too high. Broken clutch spring or worn clutch spring boss. Loose attachment holder. 	<ul style="list-style-type: none"> Set idle: 3,000 (\pm300) RPM (min^{-1}). Replace spring/shoes as required, check idle speed. Inspect and re-tighten holders securely.
Engine will not idle down.	<ul style="list-style-type: none"> Engine idle set too high. Engine has an air leak. 	<ul style="list-style-type: none"> Set idle: 3,000 (\pm300) RPM (min^{-1}). Consult with an authorized servicing dealer.
Excessive vibration.	<ul style="list-style-type: none"> Warped or damaged cutting attachment. Loose gearcase. Bent main shaft/worn or damaged bushings. Trimmer line not wound properly on spool. 	<ul style="list-style-type: none"> Inspect and replace attachment as required. Tighten gearcase securely. Inspect and replace as necessary. Rewind trimmer line.
Cutting attachment will not rotate.	<ul style="list-style-type: none"> Shaft not installed in powerhead or gearcase. Broken shaft. Damaged gearcase. 	<ul style="list-style-type: none"> Inspect and reinstall as required. Consult with an authorized servicing dealer.

The following statement only applies to United States and its territories

Shindaiwa Corporation

Federal Emission Design And Defect Limited Warranty Utility And Lawn And Garden Engines

Shindaiwa Corporation warrants to the initial purchaser and each subsequent owner, that this utility equipment engine (herein engine) is designed, built and equipped to conform at the time of initial sale, to all applicable regulations of the U.S. Environmental Protection Agency (EPA), and that the engine is free of defects in materials and workmanship that would cause this engine to fail to conform with EPA regulations during its warranty period. This emission warranty is applicable in all States, except the State of California.

For parts listed under PARTS COVERED, the dealer authorized by Shindaiwa Corporation will, at no cost to you, make the necessary diagnosis, repair, or replacement of any defective emission-related component to ensure that the engine complies with applicable U.S. EPA regulations.

MANUFACTURERS WARRANTY COVERAGE

When sold within the U.S., this engine's emission control system is warranted for a period of two (2) years from the date this product is first delivered to the original retail purchaser.

OWNER'S WARRANTY RESPONSIBILITIES

As the engine owner, you are responsible for the performance of the required maintenance listed in your owner's manual. Shindaiwa Corporation recommends that you retain all receipts covering maintenance on your engine, but Shindaiwa Corporation cannot deny a warranty claim solely for the lack of receipts or for your failure to ensure the performance of all scheduled maintenance.

As the engine owner, you should however be aware that Shindaiwa Corporation may deny your warranty coverage if your engine or a part has failed due to abuse, neglect, improper maintenance or unapproved modifications.

You are responsible for presenting your engine to the nearest dealer authorized by Shindaiwa Corporation when a problem exists.

If your Shindaiwa Dealer is unable to answer questions regarding your warranty rights and responsibilities, you should then contact your Shindaiwa Distributor.

For the name and telephone number of the Shindaiwa Distributor in your area, please call Shindaiwa Inc. at (503) 692-3070 between the hours of 8:00 AM and 5:00 PM Pacific Standard Time.

PARTS COVERED

Listed below are the parts covered by the Federal Emission Design and Defect Warranty. Some parts listed below may require scheduled maintenance and are warranted up to the first scheduled replacement of that part. The warranted parts include:

1. Carburetor Internal Components
 - Jet, Diaphragm Assembly-Metering
2. Ignition System Components
 - Ignition Coil
 - Flywheel Rotor

The emission control system for your particular Shindaiwa engine may also include certain related hoses and connectors.

LIMITATIONS

The Federal Emission Design and Defect Warranty shall not cover any of the following:

- (a) conditions resulting from tampering, misuse, improper adjustment (unless they were made by the dealer or service center authorized by Shindaiwa Corporation during a warranty repair), alteration, accident, failure to use the recommended fuel and oil, or not performing required maintenance services,
- (b) the replacement parts used for required maintenance services,
- (c) consequential parts used for required maintenance services,
- (d) diagnosis and inspection fees that do not result in eligible warranty service being performed, and
- (e) any non-authorized replacement part, or malfunction of authorized parts due to use of non-authorized parts.

MAINTENANCE AND REPAIR REQUIREMENTS

You are responsible for the proper use and maintenance of the engine. You should keep all receipts and maintenance records covering the performance of regular maintenance in the event questions arise. These receipts and maintenance records should be transferred to each subsequent owner of the engine. Shindaiwa Corporation reserves the right to deny warranty coverage if the owner has not properly maintained the engine. Shindaiwa Corporation will not deny warranty repairs, however, solely because of the lack of repair, maintenance or failure to keep maintenance records.

MAINTENANCE, REPLACEMENT OR REPAIR OF EMISSION CONTROL DEVICES AND SYSTEMS MAY BE PERFORMED BY ANY REPAIR ESTABLISHMENT OR INDIVIDUAL; HOWEVER, WARRANTY REPAIRS MUST BE PERFORMED BY A DEALER OR SERVICE CENTER AUTHORIZED BY SHINDAIWA CORPORATION THE USE OF PARTS THAT ARE NOT EQUIVALENT IN PERFORMANCE AND DURABILITY TO AUTHORIZED PARTS MAY IMPAIR THE EFFECTIVENESS OF THE EMISSION CONTROL SYSTEM AND MAY HAVE A BEARING ON THE OUTCOME OF A WARRANTY CLAIM.

If other than the parts authorized by Shindaiwa Corporation are used for maintenance replacements or for the repair of components affecting emission control, you should assure yourself that such parts are warranted by their manufacturer to be equivalent to the parts authorized by Shindaiwa Corporation in their performance and durability.

OBTAINING WARRANTY SERVICE

All repairs qualifying under this limited warranty must be performed by a dealer authorized by Shindaiwa Corporation

If any emission-related part is found defective during the warranty period, it is your responsibility to present the product to an authorized Shindaiwa dealer. Bring your sales receipts showing the date of purchase for this engine. The dealer authorized by Shindaiwa Corporation will perform the necessary repairs or adjustments within a reasonable amount of time and furnish you with a copy of the repair order. All parts and accessories replaced under this warranty become the property of Shindaiwa Corporation

To locate an authorized Shindaiwa dealer near you, contact your Shindaiwa Distributor. For the name and telephone number of the Shindaiwa Distributor in your area, please call Shindaiwa Inc. at (503) 692-3070 between the hours of 8:00 AM and 5:00 PM Pacific Standard Time.

THIS WARRANTY IS ADMINISTERED BY

Shindaiwa Inc.
11975 S.W. Herman Rd.
Tualatin OR. 97062
(503) 692-3070

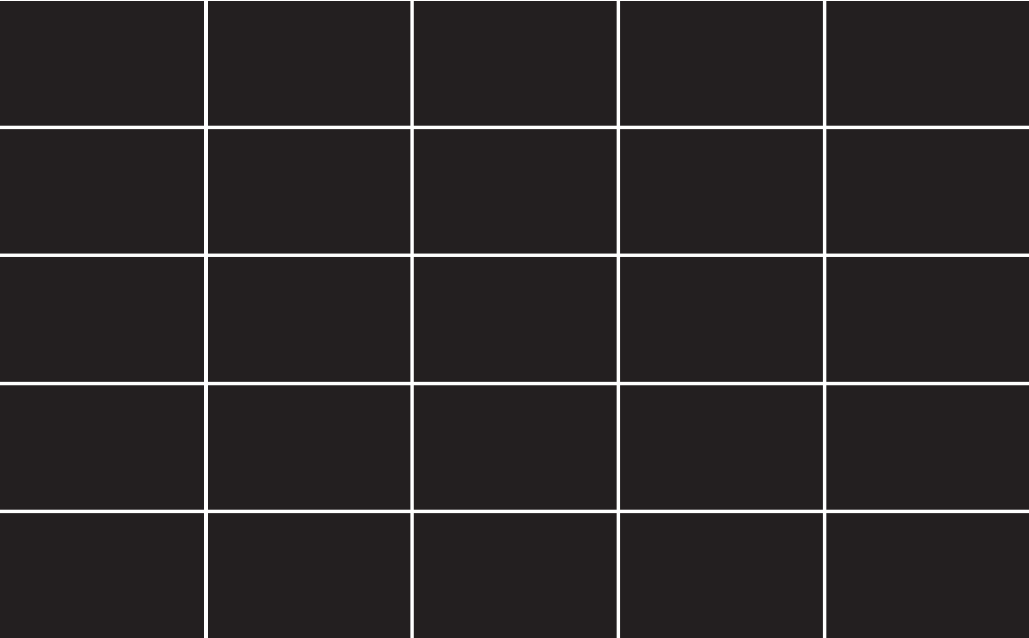

shindaiwa

Shindaiwa Inc.
11975 S.W. Herman Rd.
Tualatin, Oregon 97062 USA
Telephone: 503 692-3070
Fax: 503 692-6696
www.shindaiwa.com

Shindaiwa Corporation
Head Office:
6-2-11, Ozuka-Nishi
Asaminami-Ku, Hiroshima
731-3167, Japan
Telephone: 81-82-849-2220
Fax: 81-82-849-2481

©2007 Shindaiwa, Inc.
Part Number 62640-94313
Revision 3/07

Shindaiwa is a registered trademark
of Shindaiwa, Inc.
Specifications subject to change without notice.